

PETA PROSES BISNIS (Unit SPI)

Unit SPI :

1. Monitoring Hasil Audit Tahun Sebelumnya

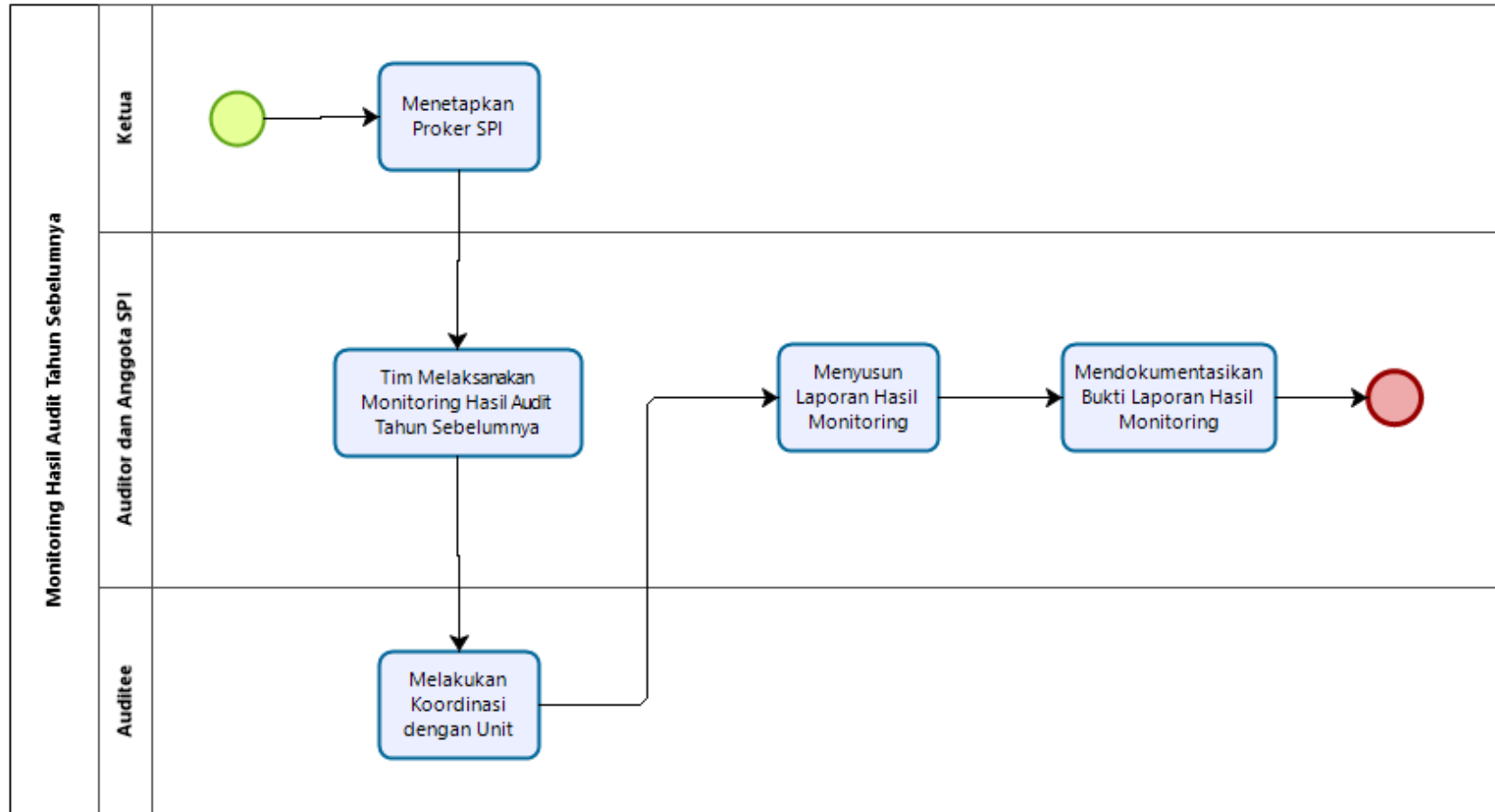

2. Audit Pelaksanaan Kegiatan

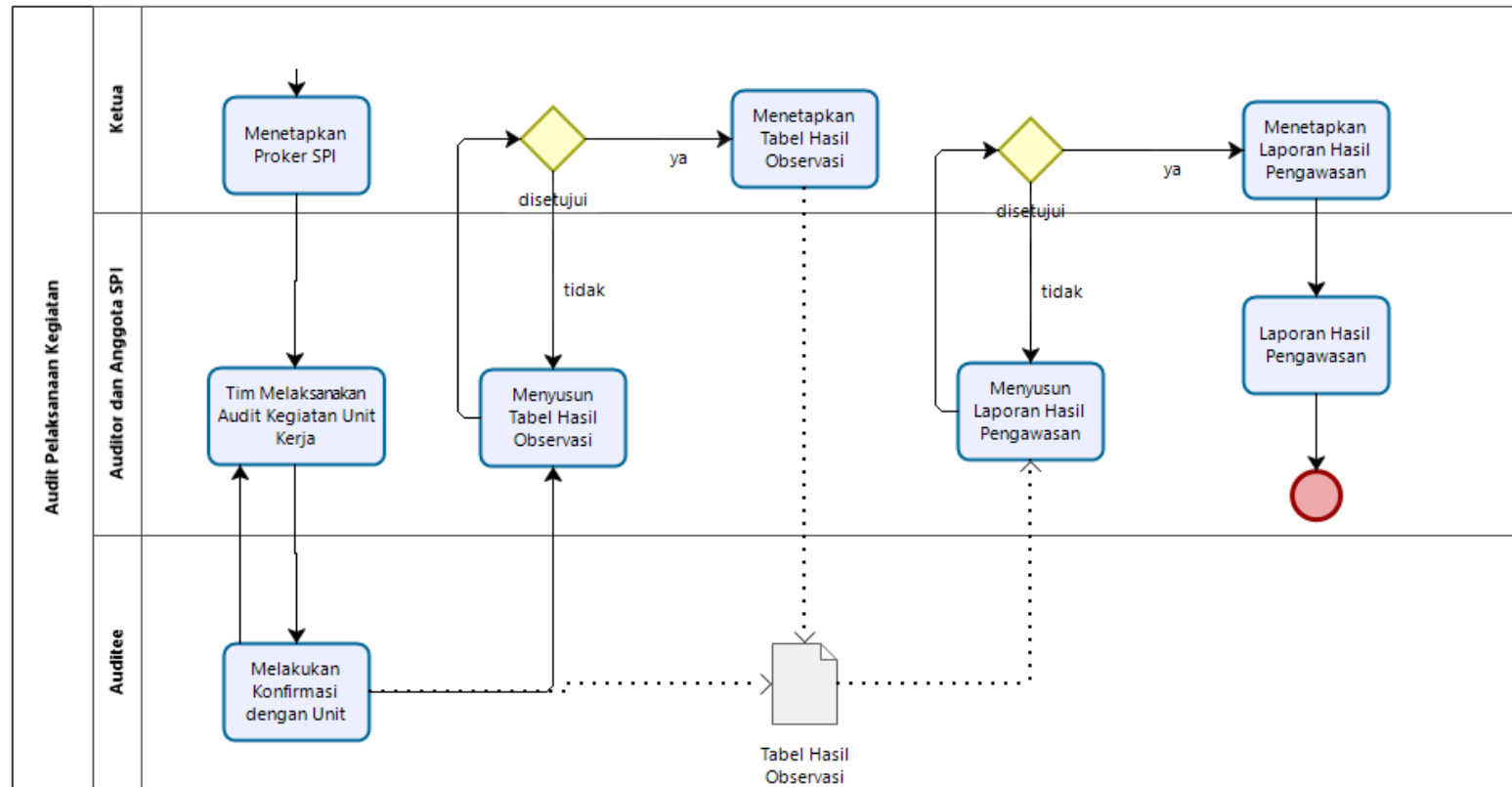

3. Review Laporan BMN

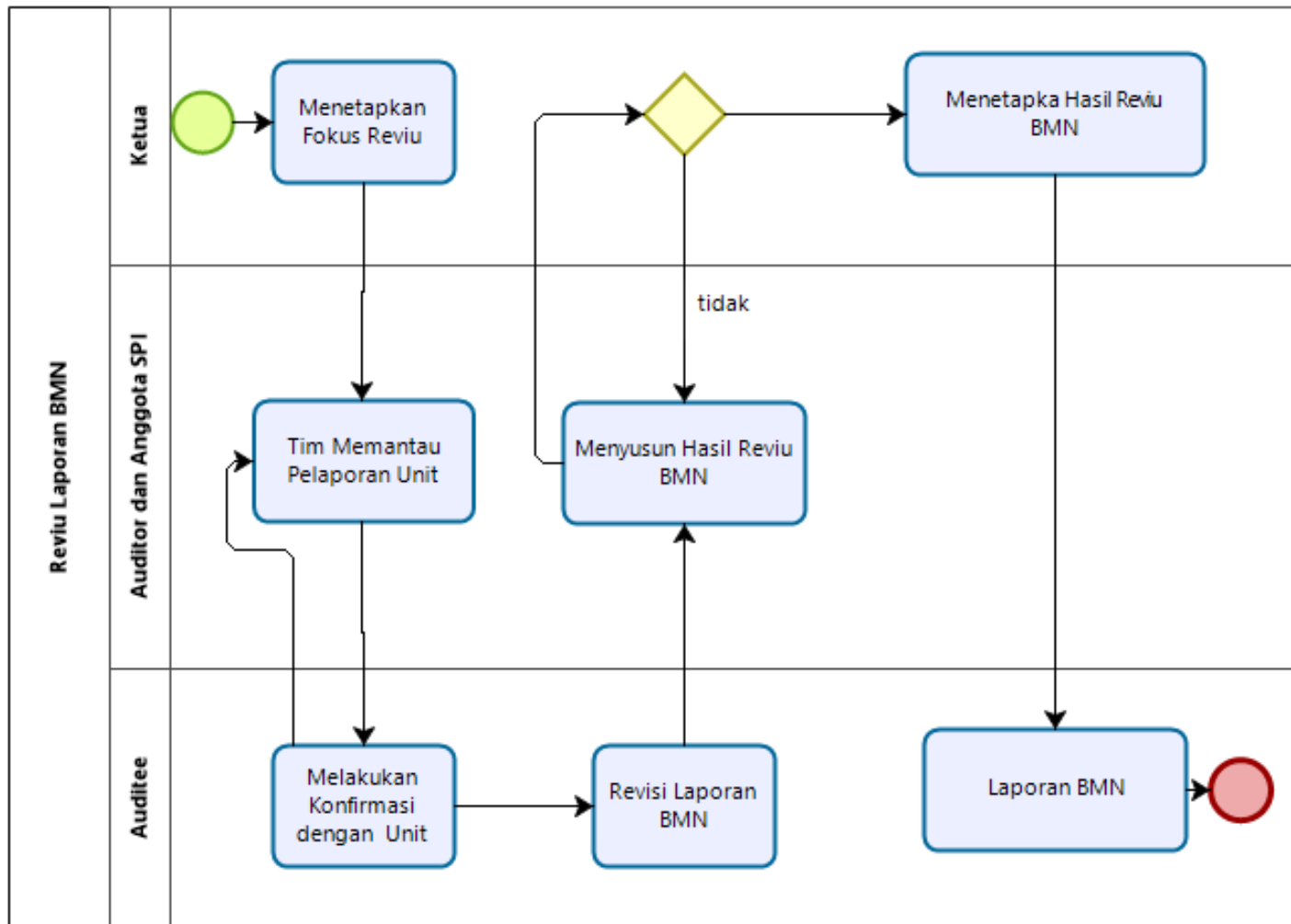

4. Pemantauan Laporan Persediaan

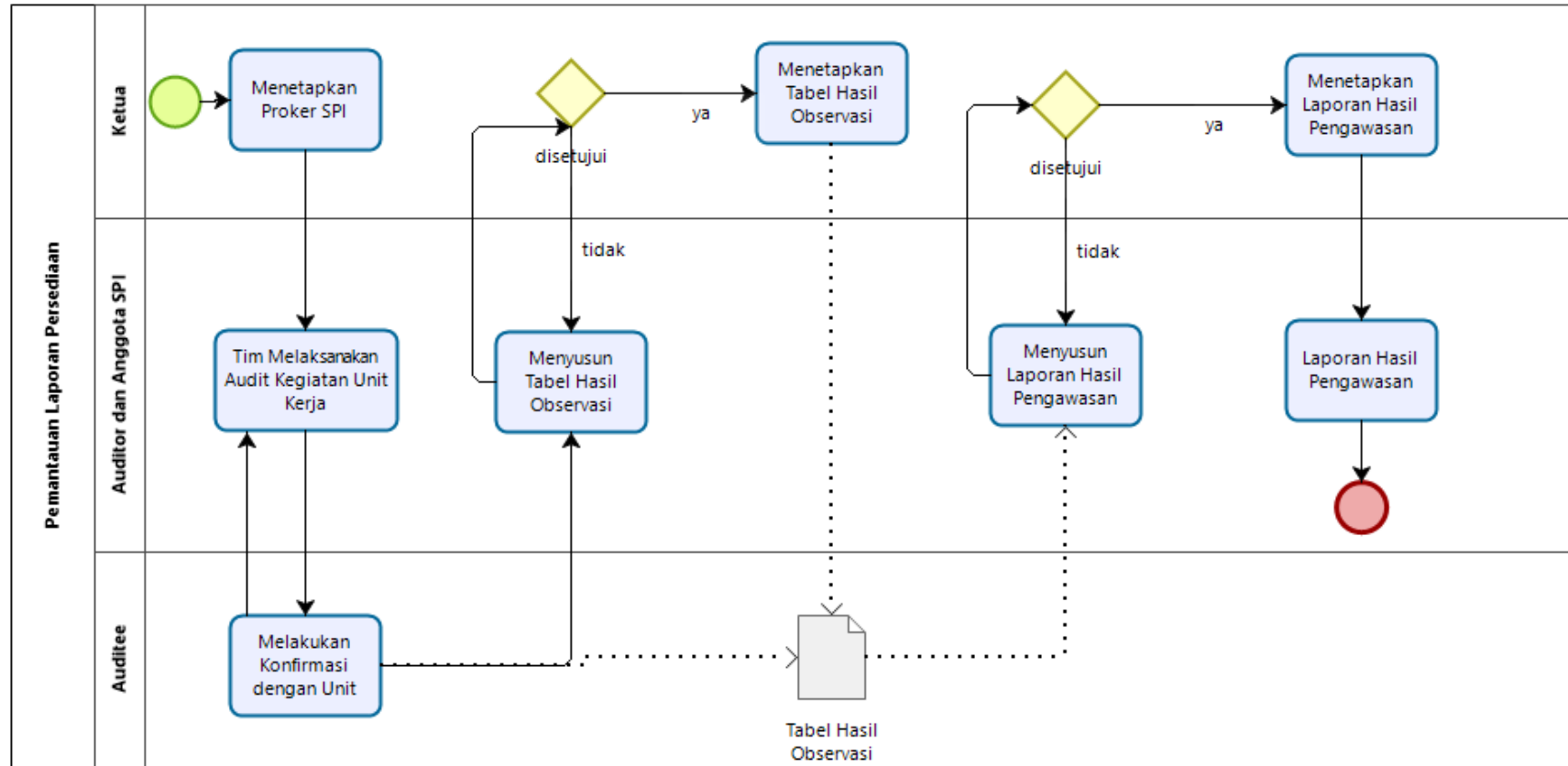

5. Pendampingan Kegiatan Pengadaan

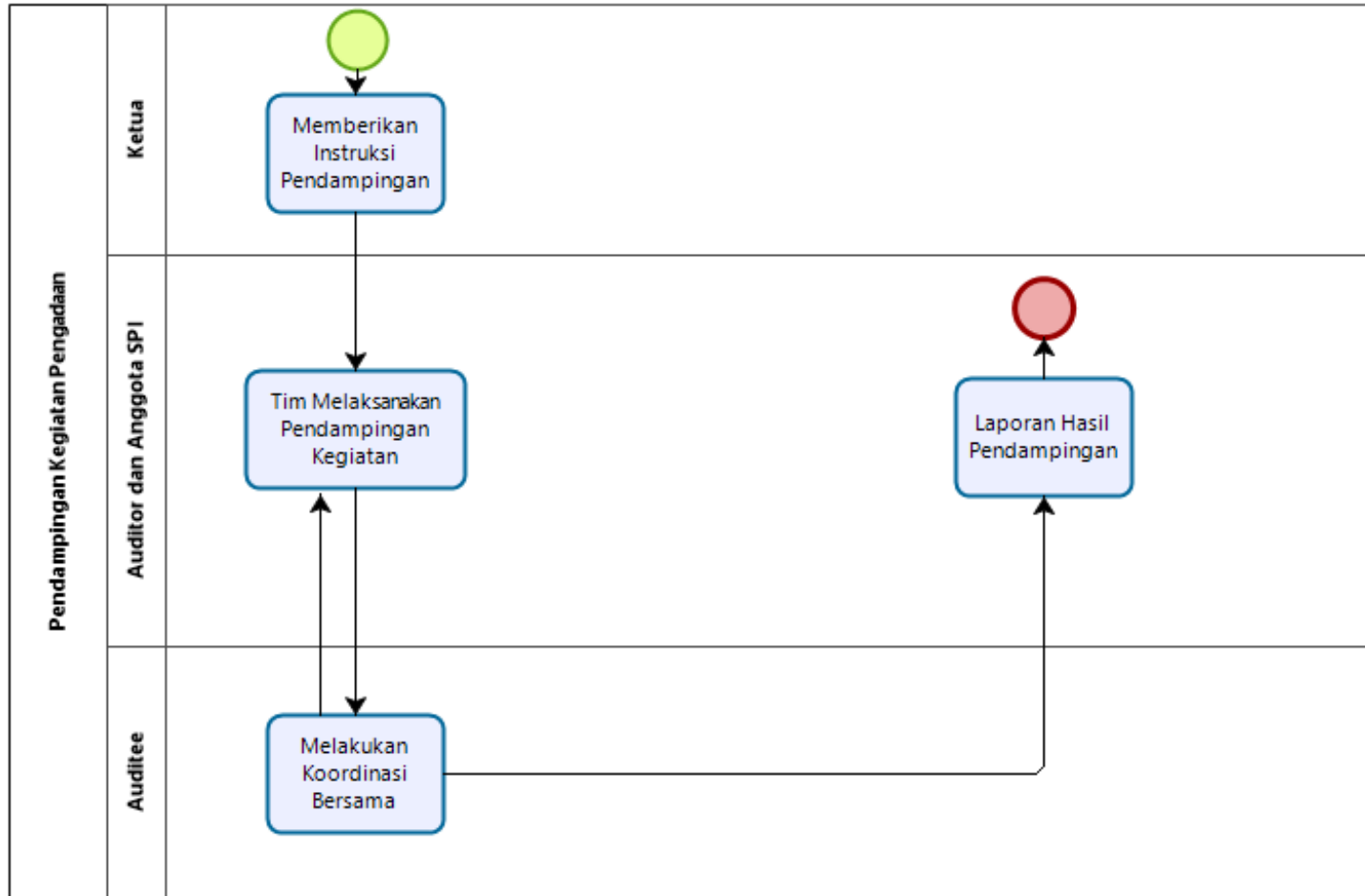

6. Review Laporan Kinerja

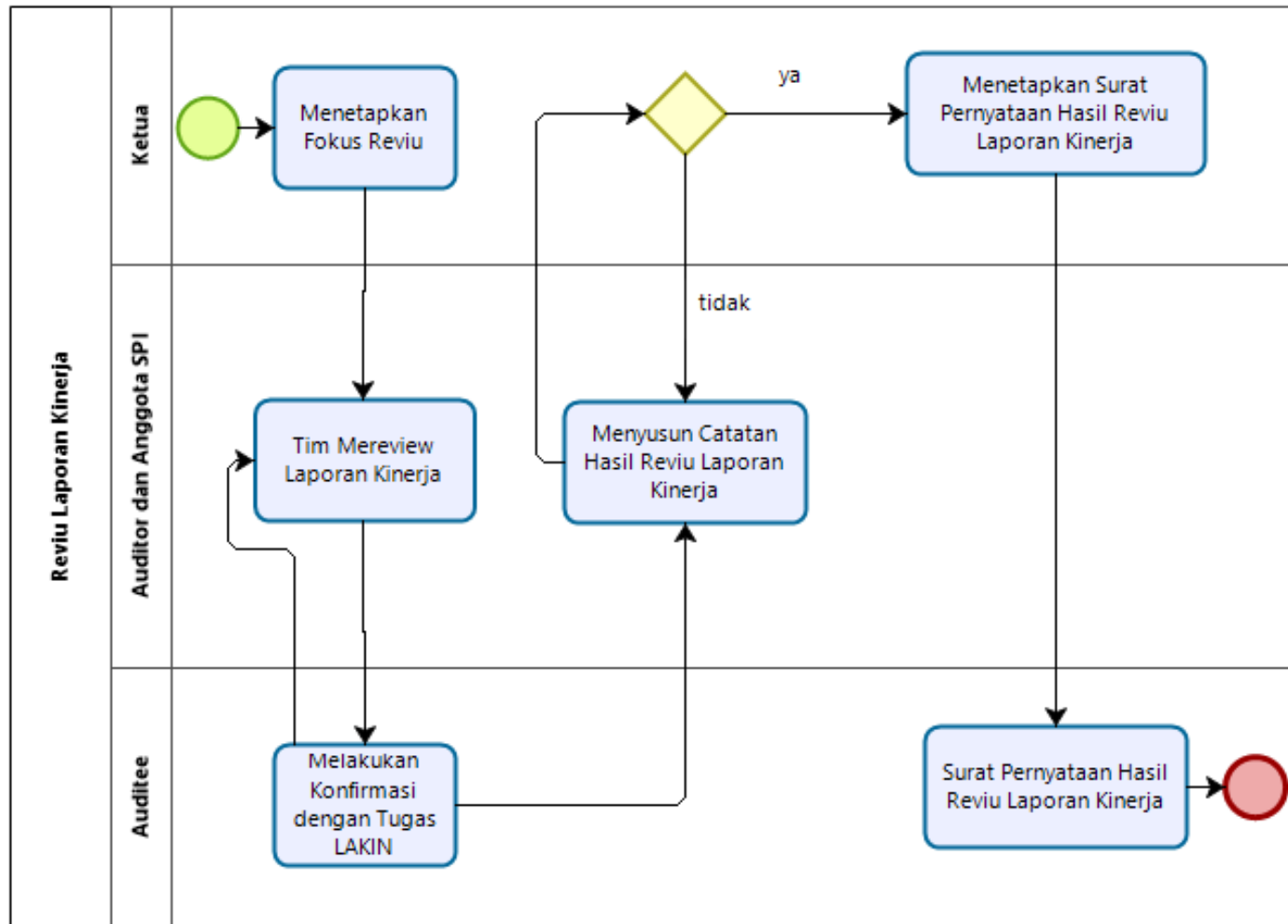

7. Informasi Hasil Pengawasan Tahunan

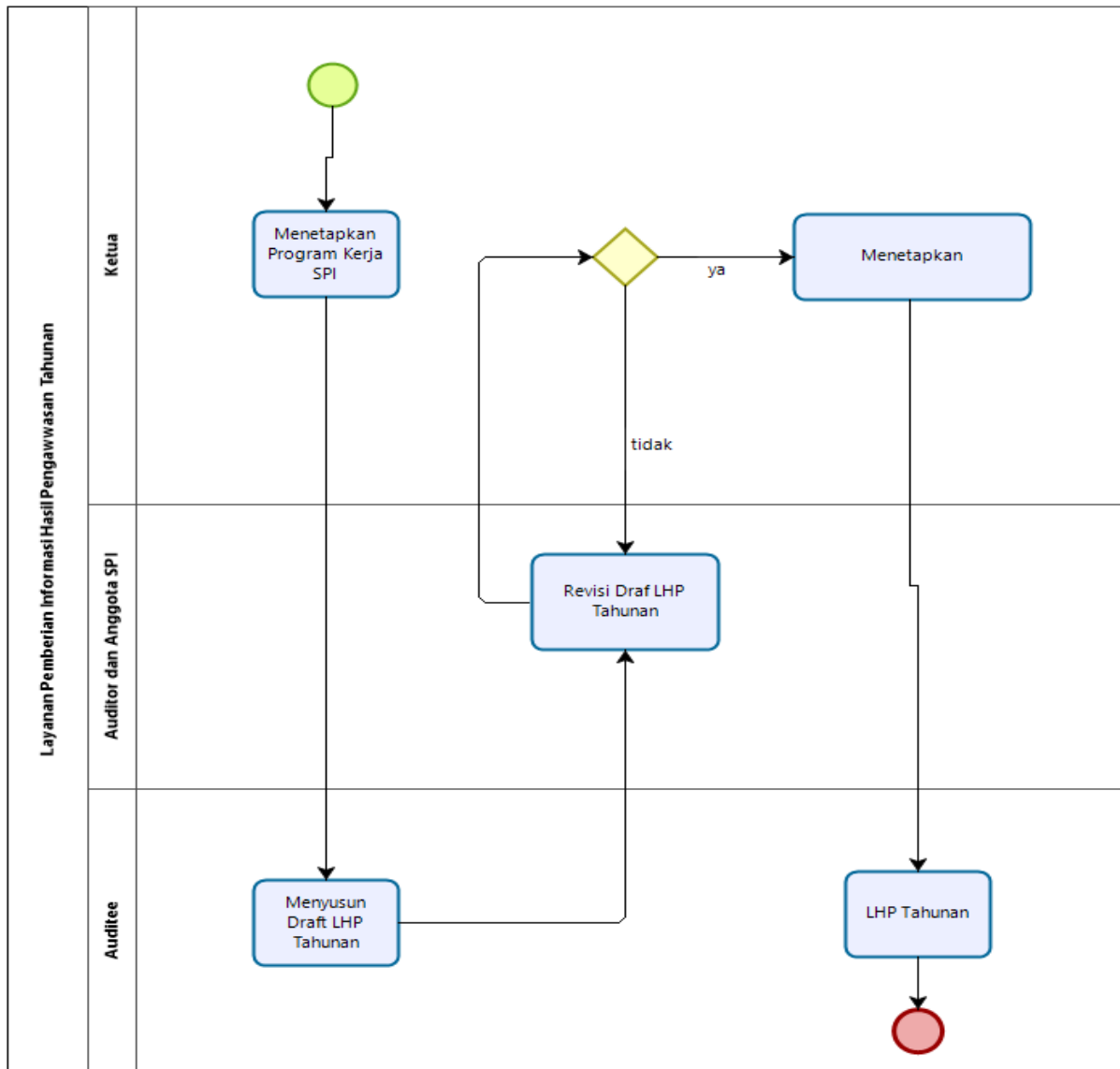

8. Informasi Hasil Pengawasan Semester

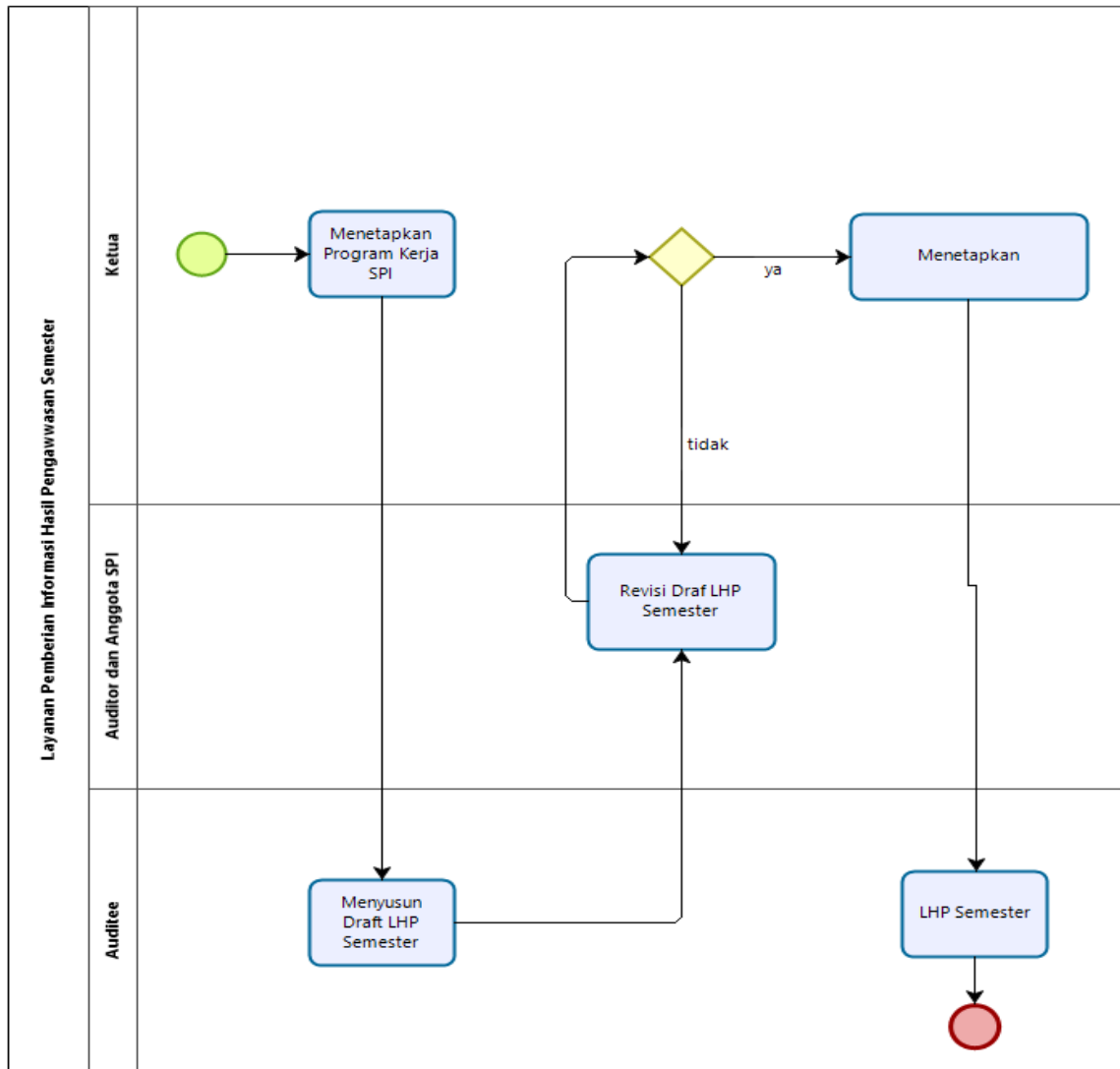

9. BPK, BPKP, Inspektorat Jenderal Kemenristekdikti dan KAP

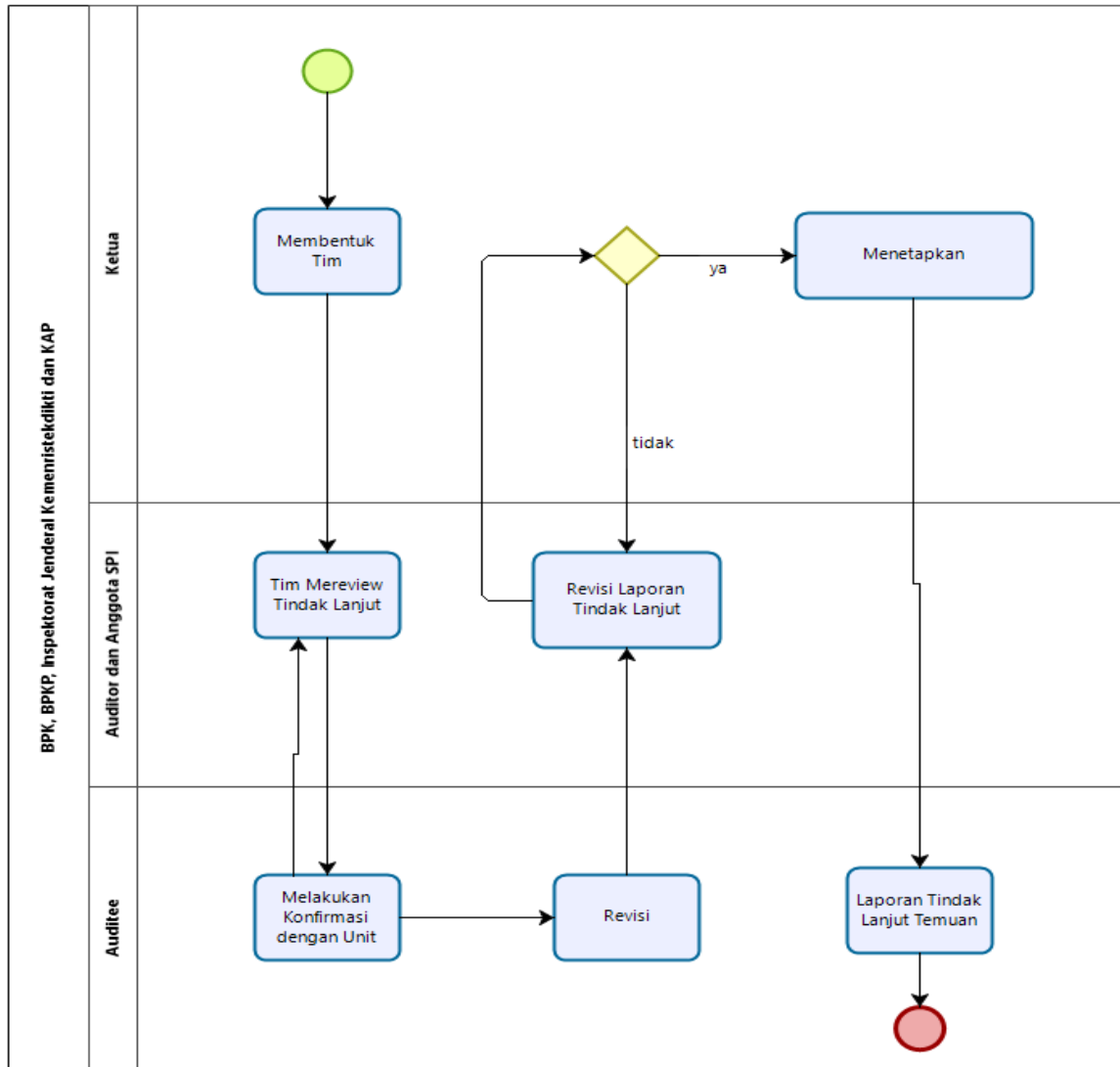

10. Review RKAKL

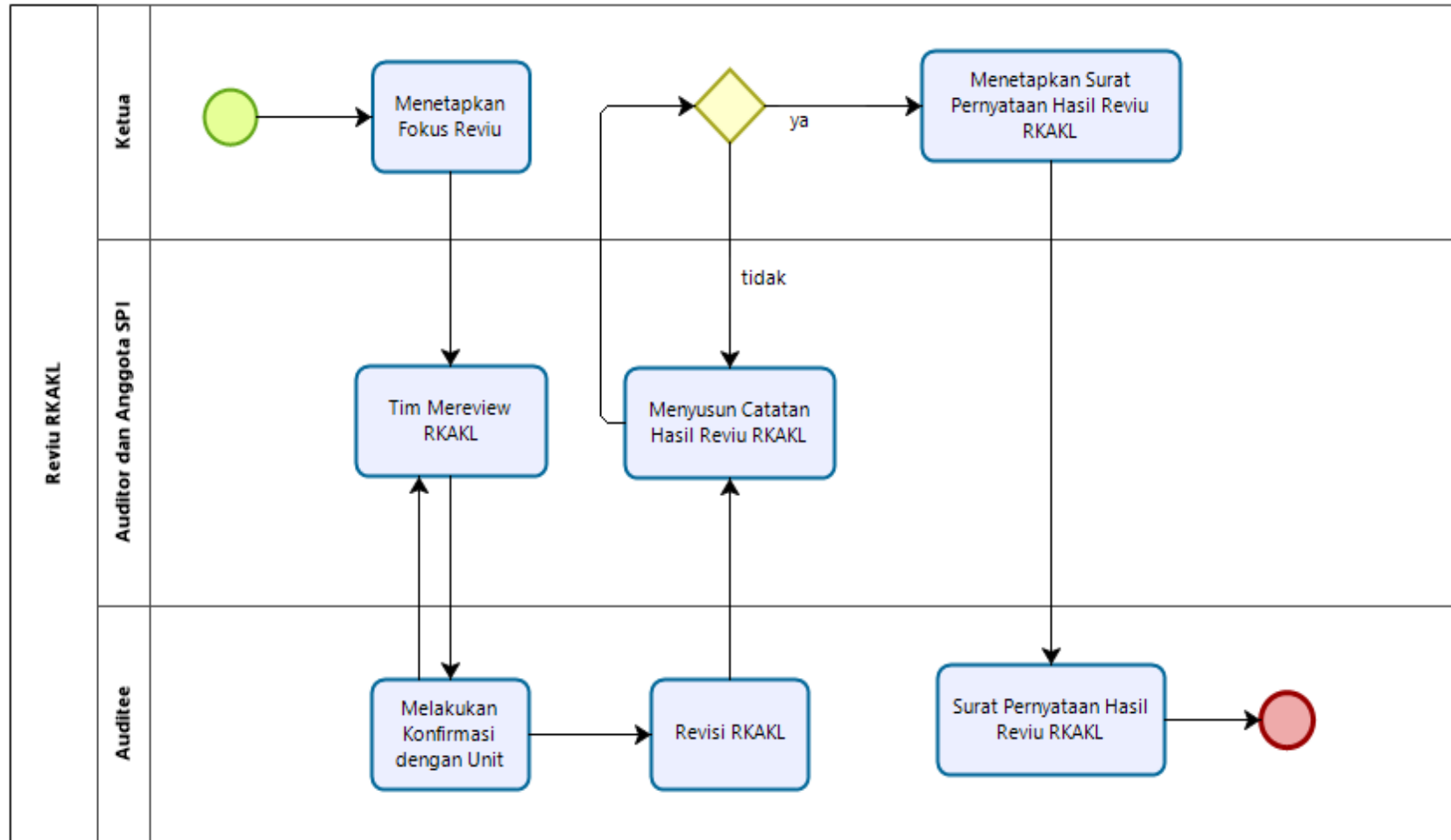

11. Review laporan keuangan

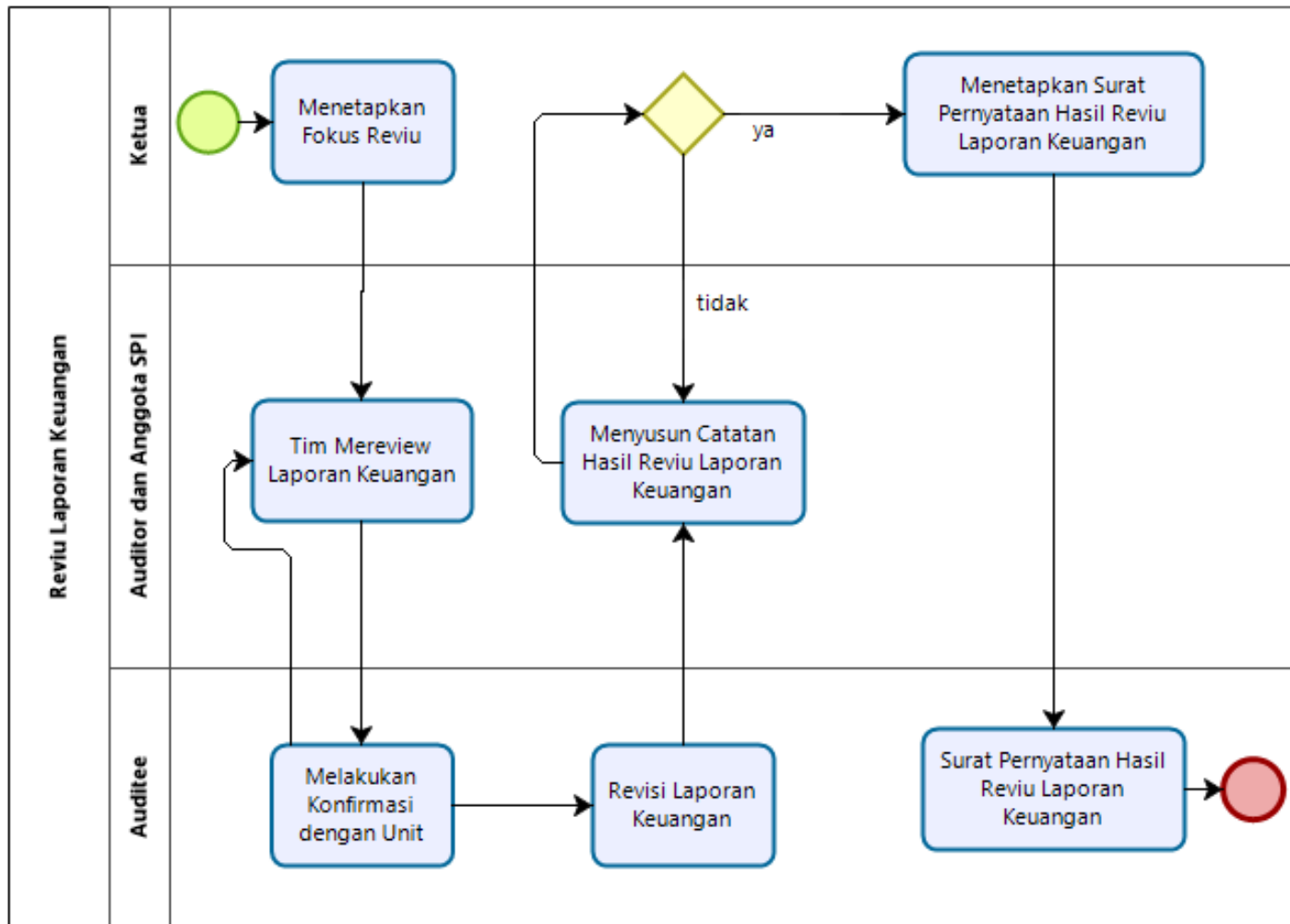

12. Penyusunan Laporan Keuangan (SAK)

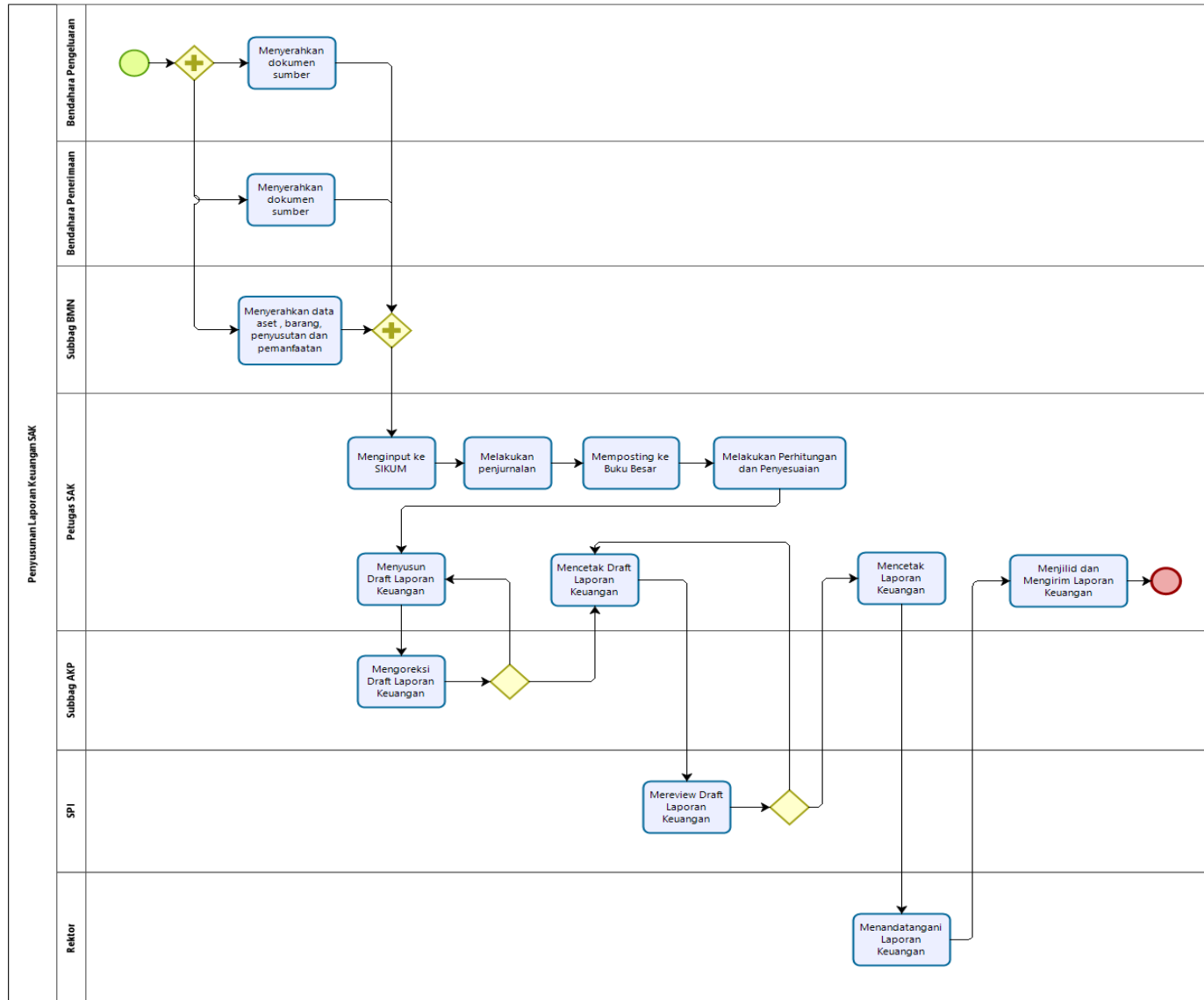

13. Pendampingan Pelaksanaan Pengelolaan Keuangan Kegiatan Unit Kerja

